



## USING VIRTUAL REALITY TO MODEL WAYFINDING BEHAVIOUR

Ian J. Ewart<sup>1</sup>

### 1 BACKGROUND AND IDENTIFICATION OF PROBLEM / KNOWLEDGE GAP

It is widely reported that Virtual Reality Environments (VRE) hold potential in the architecture, engineering and construction sectors (AEC) for providing the experience of a building at various stages prior to completion (Whyte and Nikolić, 2018). Most commonly, this includes the design phase especially as a tool for collaboration, and during construction especially as a tool to increase efficiency and identify potential mistakes. There is an implicit assumption in accepting these ideas that the representation produced and experienced in the VRE is in some way analogous to the environment that will be experienced in the Real world. Furthermore, especially in its use in the design phase and with the recognition of the importance of participatory design and stakeholder involvement, VR is seen as a tool for testing and predicting occupant behaviours. However, it is not clear to what extent the Virtual experience is representative of the Real experience, and how we should embrace and accommodate any differences. There is an acknowledged “lack of appropriate validation studies” that may be leading to the rapid uptake of VR for potentially unsuitable purposes (Nilsson and Kinatader, 2015:13). Hence the work reported here, although it focusses on wayfinding and navigation as one part of the building experience, has wider implications for the use of VR in AEC, and more specifically the use of VR data as the basis for design decisions.

### 2 RESEARCH AIM AND METHODOLOGY

This project sought to answer the question: Can a VRE assist in wayfinding and navigation around an unfamiliar Real building? To do this we produced a realistic building model (see Figs. 1a,b) in an Oculus Rift head mounted display, and set up in the entrance area of the same Real building. Volunteers completed a wayfinding task, to navigate from the entrance to a specific room, and made the journey in both the VRE and the Real building. The target room (Room 109) was chosen as it provided a limited choice of directions, with distinct signage cues (See Figure 2). Room 109 was reached from the entrance by going up the stairs and then either turning left (the shorter route) or right (the longer route). The room numbering system suggested turning right, increasing from 102 directly in front, 103 to the right, then 104 etc. although 109 is actually more than halfway around. Participants were divided into two groups – GROUP 1 carried out the task in the VRE first, then the Real building; GROUP 2 carried out the task in the Real building first, then the VRE. A total of 60 journeys were recorded, including the time and route taken (see Figs.3a -d below).



Figures 1a, 1b: Stairs as seen in the Real Environment (RE) left, and Virtual Environment (VRE) right. Participants had to decide whether to turn left or right at the top of the stairs

### 3 RESEARCH FINDINGS

Figures 3a-d summarise the results, and show that both Groups made similar choices in their route selection, with a far greater proportion taking the shorter route second time around, whether this was in the VRE or Real building, with a consequently similar reduction in average time taken. Taken at face value, this suggests that an immersive Virtual Reality Environment can be used to model and predict the behaviour of occupants in wayfinding and becoming familiar with the layout of a building. However, we also noted subtle but important differences in the way the two environments were experienced, including greater risk taking in the VRE (e.g. jumps), and more head movement in

<sup>1</sup> Lecturer, School of the Built Environment, University of Reading. [i.j.ewart@reading.ac.uk](mailto:i.j.ewart@reading.ac.uk)

the Real environment. Therefore, we need to adopt a cautious approach when designing by VR, and recognise that the results of behaviour tests in a VRE should complement design decisions, rather than act as their sole justification.

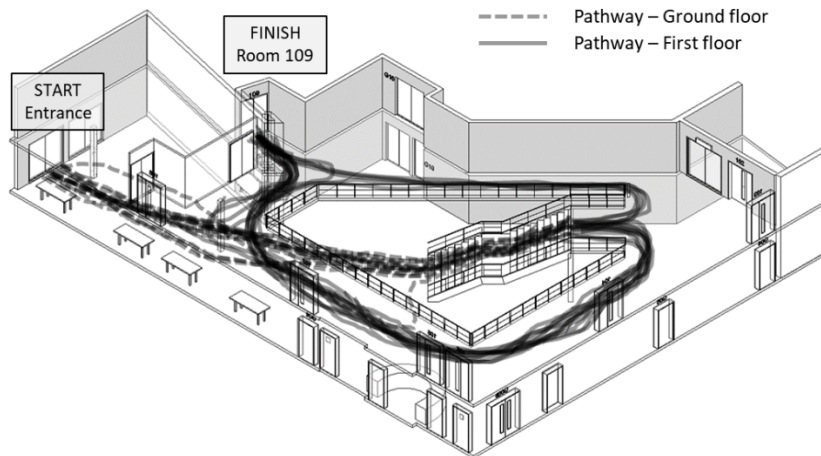

Figure 2: Isometric view of the Case Study building, showing Wayfinding Task 'Start' and 'Finish', and individual routes taken. Note the choice of two primary routes: turning left or right at the top of the stairs.

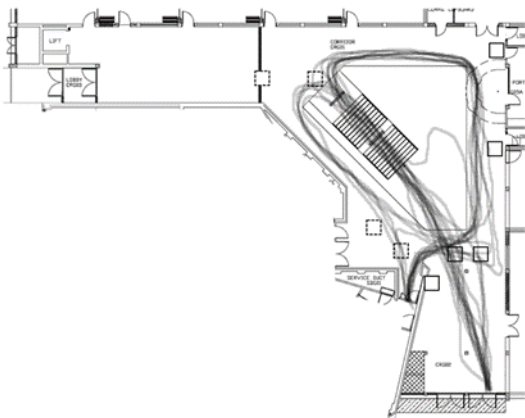

Fig. 4a: GROUP1 VR first (average time: 43.9secs)

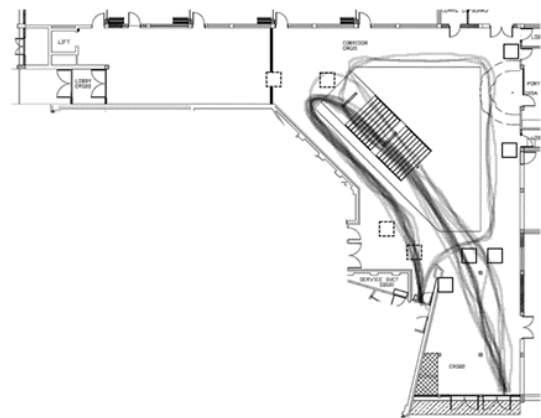

Fig. 4b: GROUP1 Real second (average time 39.9secs)

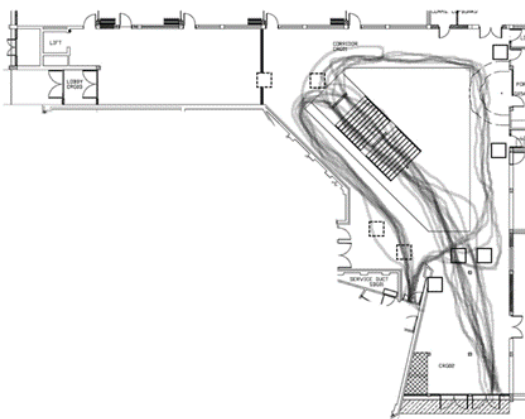

Fig. 4c: GROUP2 Real first (average time: 46.6secs)

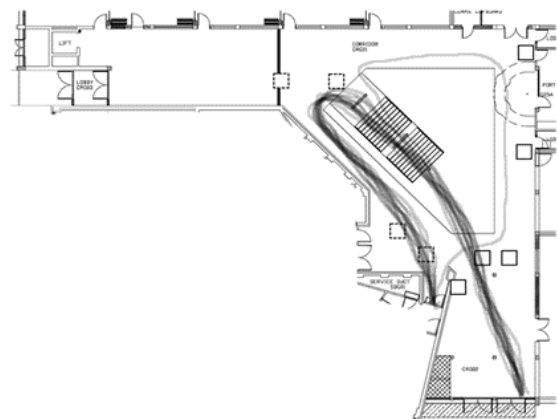

Fig. 4b: GROUP2 VR second (average time 35.0secs)

#### 4 REFERENCES

Nilsson, D. and Kinateder, M. 2015. Virtual reality experiments – the future or a dead end? Proceedings of the 6th International Symposium on Human Behaviour in Fire, Cambridge. 13-22.  
 Whyte, J and Nikolić, D. 2018. Virtual Reality and the Built Environment. London: Routledge.