



## MODELLING INDOOR AIR QUALITY IN SCHOOLS USING GREY BOX MODELS

Juan Tugores, Marcel Macarulla, Marta Gangolells, Miquel Casals

Universitat Politècnica de Catalunya, Group of Construction Research and Innovation (GRIC), Spain

### Abstract

Current indoor air quality strategies are based on the measurement and control of carbon dioxide (CO<sub>2</sub>) indoor concentration. Most educational buildings rely only on natural ventilation, making indoor air quality highly dependent on weather conditions. Therefore, to ensure the safety and well-being of students and teachers, it is necessary to determine the factors influencing CO<sub>2</sub> concentration in naturally ventilated spaces. The aim of this paper is to estimate the students' CO<sub>2</sub> emission rates in naturally ventilated classrooms using grey box models.

### Introduction

Indoor air quality refers to the air quality within and around buildings and structures, especially as it relates to the health and comfort of building occupants. Human beings spend approximately 90% of their time (more than 21 hours per day) in indoor environments such as homes, schools, offices, and restaurants (Mannan & Al-Ghamdi, 2021). Staying in a stuffy and poorly ventilated environment is harmful for the user in the long term, who may develop conditions such as asthma, respiratory diseases, or chronic lung diseases (Manisalidis et al., 2020). Therefore, having good indoor air quality in buildings is essential to reduce the negative impact on human health (Yang et al., 2022).

Indoor air quality is critical in educational buildings, particularly in schools. Children are the most vulnerable group to air contaminants because they breathe more air in proportion to their body weight and because their lungs are still developing. (Tunga et al., 2022).

The actual indoor air quality regulation is focused on the control of the indoor concentration of carbon dioxide gas (CO<sub>2</sub>). This is one of the intrinsic gases in buildings as it is an essential part of the user's metabolic system. Although it is not considered a harmful gas per se, studies have suggested that being exposed above 1,000 ppm in the short term affects cognitive performance decision-making, and problem solving of humans (Azuma et al., 2018).

In areas with a Mediterranean climate, most schools rely on natural ventilation to provide adequate indoor air quality. High initial investments and energy savings is most likely one of the main reasons why mechanical ventilation systems are missing in about 8,000 educational

institutions in the Mediterranean region's school building portfolio (Alonso et al., 2021). However, due to the variability of weather conditions, in most cases, natural ventilation does not ensure proper air renewal for reducing the CO<sub>2</sub> concentration to healthy levels. Moreover, maintaining natural ventilation under certain conditions can negatively affect the thermal comfort of users (Heracleous & Michael, 2019) and lead to an increase in the energy consumption of heating systems (Franco & Leccese, 2020).

In this context, knowledge of the CO<sub>2</sub> generation rates and ventilation air change rates in uncontrolled spaces is crucial to efficiently monitoring indoor air quality and reducing energy consumption related to the thermal comfort of the occupants.

Monitoring indoor air quality is straightforward, low-order state space models are typically developed using a deterministic methodology. However, only a small number of studies in the field of indoor CO<sub>2</sub> concentration use grey box models to address statistical approaches (Macarulla et al., 2018). The stochastic approach can be used to deal with potential system disturbances that the deterministic models have, like the impact of unaccounted-for, unmodeled inputs, measurement noise, or managing uncertainties that have an impact on the system (Macarulla et al., 2017). As a result, statistical techniques can be employed to obtain appropriate models.

Based on the shortcomings exposed, the goal of this paper is to determine the children's CO<sub>2</sub> generation rate in naturally ventilated educational buildings using grey box models. The statistical approach for estimate the CO<sub>2</sub> emission rate provide a more accurate model to predict CO<sub>2</sub> indoor concentrations that can be implemented on ventilation systems.

### Background

Grey box modelling is in between two well-known modelling methodologies, white box and black box modelling. The grey box fits results using knowledge of the physical aspects of the system and empirical statistical data observed. It consists of a set of stochastic differential equations describing the dynamics of the system in continuous time and a set of discrete time measurements.

For the implementation of grey box modelling, it is necessary to define a system of ordinary equations to express the physical knowledge, known as drift term,

defined by the function  $f(X_t, U_t, \theta, t)$ . To introduce the variations that are not described by the deterministic model, a stochastic term or diffusion term is added. Equation (1) expresses the system of stochastic differential equations:

$$dX_t = f(X_t, U_t, \theta, t)dt + G(\theta, t)dw_t \quad (1)$$

where  $X_t$  is a vector of system states,  $U_t$  corresponds to experimental data, and  $\theta$  is the vector of unknown parameters of the system. The diffusion term is composed of a standard Weiner process,  $W_t$ , and a function describing the disturbance,  $G(\theta, t)$ , known as drag term.

Secondly, the state-space representation is completed by defining the discrete time observation:

$$Y_{t_k} = h(X_{t_k}, U_{t_k}, \theta, t)dt + e_t \quad (2)$$

where the function  $h(X_t, U_t, \theta, t)$  links the state variables with the measurements, and  $e_t$  is a Gaussian distribution that represents the noise from the observations.

The objective of the modelling is to estimate the unknown parameters ( $\theta$ ) in the continuous-time model. Generally, the maximum likelihood estimation (MLE) method is used (Bacher & Madsen, 2011). The MLE is based upon the premises that, of all possible parameters, the most suitable ones are those that are most consistent with the observed data. Finally, with the same data observation used for determining  $\theta$ , the grey box model is validated by using the described state equations and the estimated parameters.

The advantages of grey box models (such as being straightforward, reliable, quick, and computationally effective) have led to their widespread use in a variety of applications in the building energy domain (Li et al., 2021).

Grey box modelling approach has been also successfully used to predict the thermal behaviour of a building (Brastein et al., 2018), estimating the thermal properties

of the walls using indoor temperatures and electrical power as discrete observations.

According to indoor air quality, previous researches have used grey box models to estimate the human CO<sub>2</sub> generation rate (Macarulla et al., 2017) and ventilation air flows (Macarulla et al., 2018) in offices. These studies applied physical knowledge of a carbon dioxide mass balance with data observation about occupancy, mechanical ventilation, and indoor CO<sub>2</sub> concentration. Other studies have used the same methodology to predict indoor air quality by estimating the occupancy in naturally and mechanically ventilated environment (Wolf et al., 2019).

## Methodology

This section shows the methodology used to estimate the human CO<sub>2</sub> generation rate in a classroom that is fully naturally ventilated by using grey box modelling.

### Data collection

Data used to develop the grey box model was collected within the IAQ4EDU project (Gaspar et al., 2022). Two classrooms were selected (Figure 1) from different climatic zones, C2 and D3 (Spanish Government, 2022), respectively.

The first classroom (A1) is located on the first floor and accommodates children from 4 to 5 years old. It has an area of approximately 48.38 m<sup>2</sup> and a volume of 145.87 m<sup>3</sup>. The ventilation is fully natural, has 4 windows with 1.74 m<sup>2</sup> of surface each, and 2 doors, one connected to the corridor (1.70 m<sup>2</sup>) and another that leads to a small bathroom (1.68 m<sup>2</sup>).

The second classroom (A2) is located on the first floor and accommodates children from 9 to 10 years old. It has an area of approximately 51.54 m<sup>2</sup> and a volume of 146.90 m<sup>3</sup>. The ventilation is mixed, natural and mechanical, but the air flow system was shut down during the whole monitoring period. The room has 5 windows of 1.11 m<sup>2</sup> each and 1 door that leads to the corridor of 1.65 m<sup>2</sup>.

Classroom A1

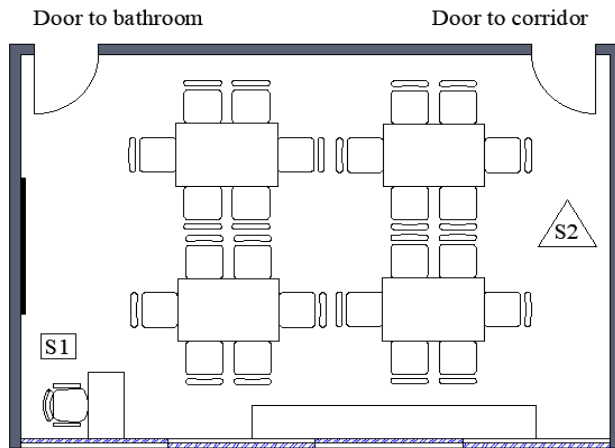

Classroom A2

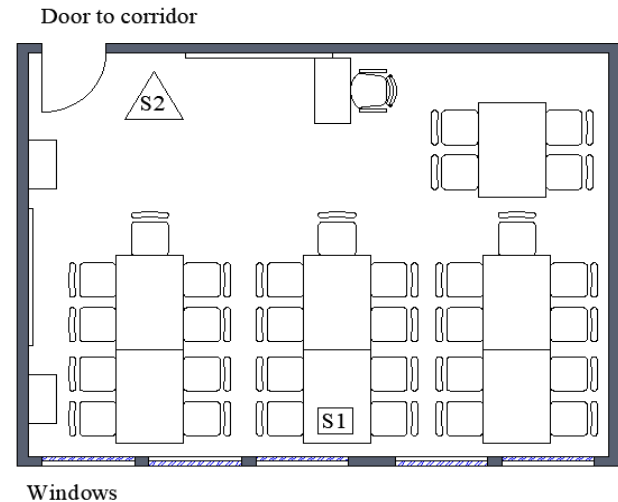

Figure 1: Layout of A1 (left) and A2 (right) classrooms and corresponding sensor location

Figure 2 presents the data set used to develop the grey box model. The first plot shows the CO<sub>2</sub> concentration observed inside the room by the sensors (S1, S2), the second shows the occupancy of the room (P), and the last plot presents the process of opening and closing windows (W) and doors (D). Occupation and ventilation behaviour were registered manually by the researcher. During the entire monitoring period, the occupants remained seated and relaxed (metabolic activity of 1.2 MET).

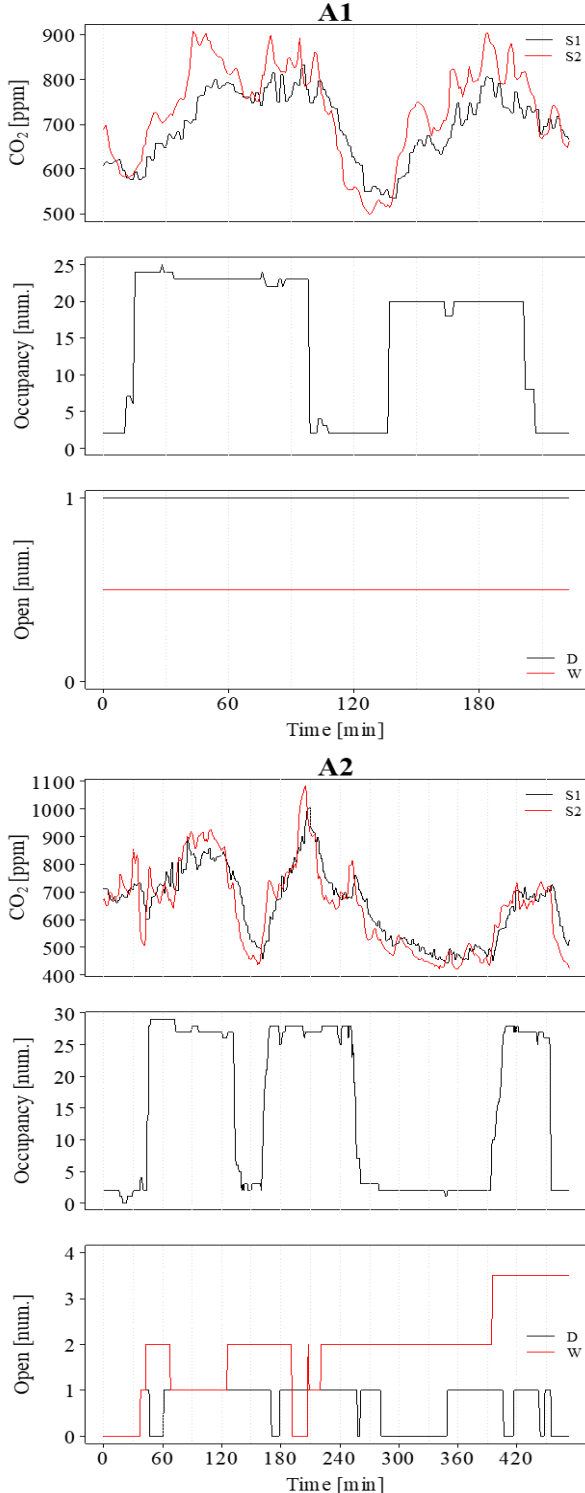

Figure 2: Data set from A1 (top) and A2 (bottom) classrooms

Measurements were carried out in April 2022. Table 1 shows the monitoring period for each space, which corresponds to the scholar schedule of the class period.

Table 1: Monitoring period

Classroom	Date [dd/mm/yyyy]	Start [hh:mm]	End [hh:mm]
A1	05/04/2022	09:22	13:05
A2	22/04/2022	08:20	16:12

Two sensors were placed in different locations of the classroom (Figure 1) in order to observe differences in CO<sub>2</sub> levels. The first sensor (S1) is a Comet sensor model U3430, which is designed to record air temperature, relative humidity, CO<sub>2</sub> concentration levels. The second sensor (S2) is a Delta OHM, HD32.3TC, a microclimatic thermal station for the measurement of dry bulb temperature, natural ventilation, wet bulb temperature, globe thermometer temperature, relative humidity, air speed, carbon dioxide concentrations, and atmospheric pressure.

Both sensors operate without the need for an electrical connection, and their size makes them easier to place in rooms without causing disruption.

### Model development

In this paper, the deterministic function implemented in the grey box model is based on the principle of mass balance in a designated volume. Indoor CO<sub>2</sub> concentration change ( $C_{int}$ ) in the classroom is expressed as:

$$\frac{dC_{int}}{dt} \cdot V_i = Q_{ven} \cdot (C_{ven} - C_{int}) + P \cdot K_{occ} \quad (3)$$

where  $V$  is the volume of the designated classroom,  $C_{ven}$  is the CO<sub>2</sub> outdoor concentration,  $Q_{ven}$  is the ventilation rate,  $P$  is the occupancy of the room, and  $K_{occ}$  is the CO<sub>2</sub> emission rate per occupant.

Equation (3) assumes 4 hypotheses: i) CO<sub>2</sub> is chemically stable and inert, and there is no absorption process that can reduce it; ii) walls, ceilings, and furniture do not absorb CO<sub>2</sub>; iii) the CO<sub>2</sub> occupies the entire room; iv) the different ventilation air flows are constant.

In naturally ventilated buildings, the air flow is considered a form of behavioural adaptation when people are able to make the environmental adjustments themselves, for example, by opening or closing windows or doors (Yoon et al., 2022). Consequently, the air flow is primarily wind driven due to pressure, temperature, and humidity changes between the outside and the inside (Jiang et al., 2022).

The conditions of natural ventilation are also influenced by occupancy behaviours, i.e., opening and closing windows and doors (Di Gilio et al., 2021; Yoon et al., 2022). In order to take these influences into account, the air flow rate is calculated using the following equation:

$$Q_{ven} = (1-x) \cdot (W \cdot Q_w + D \cdot Q_d) + x \cdot (W+D) \cdot Q_x \quad (4)$$

where  $W$  and  $D$  refer to the number of opened windows and doors, respectively,  $Q_w$  and  $Q_d$  represent the single sided ventilation, and  $Q_x$  is the cross-ventilation air flow. This parameter represents the air flow with the best performance of indoor air quality and is controlled by the binary variable  $x$ , which is 1 when both doors and windows (or any other similar element on correspond opposite sides) are open and 0 on the contrary.

Equation (4) assumes that there is no infiltration into the classrooms. Consequently, the reduction of CO<sub>2</sub> concentrations is caused only by opening of windows and doors. The deterministic system expressed by Equation (3), with the clarification of Equation (4), can be represented as a RC-network (Figure 3).

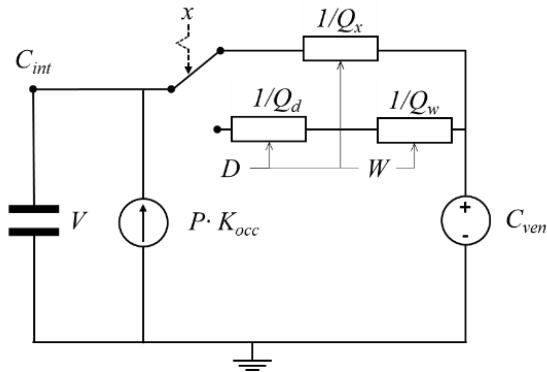

Figure 3: RC-network of the used model

A stochastic term is added to complete the equation:

$$dC_{int} = \frac{Q_{ven}}{V} (C_{ven} - C_{int}) \cdot dt + \frac{P \cdot K_{occ}}{V} \cdot dt + \sigma \cdot dw \quad (5)$$

where  $dw$  is the Weiner process, and  $\sigma$  is the incremental variance of the process. Finally, the monitored output of the system is defined by the Equation (6):

$$Y_{t_k} = C_{int,t_k} + e_k \quad (6)$$

where  $C_{int,t_k}$  is the observation at  $t_k$  of the CO<sub>2</sub> indoor concentration of the classroom, and  $e_k$  represents the measurements' noise.

### Estimation of the unknown parameters

The objective of the presented model is to estimate the human emission rate of CO<sub>2</sub> ( $K_{occ}$ ). For this reason, the inputs to the model are the volume of the room ( $V$ ), the occupancy ( $P$ ), and the behaviour of the windows, and doors ( $W, D, x$ ).

Additionally, the natural ventilation rates ( $Q_d$ ,  $Q_w$ , and  $Q_x$ ), and the outdoor CO<sub>2</sub> concentration ( $C_{ven}$ ) shall be determined in order to complement the model. Ranges for the unknown parameters have to be set, based on the physical sense and the existing literature (Table 2).

Measuring the atmospheric value of outdoor CO<sub>2</sub> concentrations is a difficult task because CO<sub>2</sub> is not homogeneous in the atmosphere. Previous studies have quantified the outdoor concentration as 420 ppm for urban locations according to several data points from South European cities (CSIC, 2020).

Table 2: Parameter boundaries

Parameter	Initial value	Lower bound	Upper bound
$C_{ven}$ [ppm]	1000	400	3,000
$Q_d$ [m <sup>3</sup> /h]	900	0	3,600
$Q_w$ [m <sup>3</sup> /h]	900	0	3,600
$Q_x$ [m <sup>3</sup> /h]	900	0	3,600
$K_{occ}$ [l/h]	9	0	18
$\sigma$ [-]	1	Exp (-20)	Exp (20)
$e_k$ [-]	1	Exp (-50)	Exp (50)

Various governments have published guides with requirements regarding the ventilation air flows needed to control the CO<sub>2</sub> indoor concentration levels (Lepore et al., 2021) in educational buildings. According to the ASHRAE Standard 62.1, (ASHRAE, 2019), at educational buildings and offices, an outdoor fresh air renewal of 18 m<sup>3</sup>/h per person (5 l/s per person) is recommended to maintain a good indoor air quality. However, the Spanish Regulation of Thermal Installations in Buildings (Spanish Government, 2021) establishes a ventilation flow rate of 45 m<sup>3</sup>/h per person (12.5 l/s per person) for good indoor air quality. Assuming an occupancy of 20 students, the required ventilation flow, according to these regulations must be of 900 m<sup>3</sup>/h.

According to the literature, the human emission rate of CO<sub>2</sub> ( $K_{occ}$ ) for an adult is 18 l/h (Macarulla et al., 2018). Table 3 summaries children's CO<sub>2</sub> emission rate (Persily & de Jonge, 2017). All values presented refer to controlled conditions.

Table 3: CO<sub>2</sub> generation rates at 20°C and 101 kPa based on the age range and the level of physical activity

Age [years]	CO <sub>2</sub> generation rate [l/h]		
	Level of physical activity [MET]		
	1.0	1.2	1.4
3 to 6	7.0	8.4	9.8
6 to 11	9.2	11.1	12.9

The CTSM-R version 1.0.0 package for R (CTSM-R Development Team, 2021) is used for estimating the parameters and validating the grey box model. A 2.60 GHz Intel Core i7 personal computer was used.

### Model validation

The first step consists on determining whether the estimated parameters are feasible in terms of the system's physical sense. For this purpose, the results need to be compared to those presented in the literature.

First, a significance test is performed. The parameters must have a probability value lower than 0.05; if not, they

are considered to be non-significant (CTSM-R Development Team, 2021). The derivative of the objective function with respect to the particular initial state or parameter is then calculated. If the value is not close to zero, the solution is not likely to be a true optimum. The derivative of the penalty function with respect to the specific initial state or parameters is then calculated. If this value is significant, the parameter may be approaching one of its boundaries. As a result, the estimation must be repeated with new limits (CTSM-R Development Team, 2021).

Secondly, the correlation matrix of the parameter is also calculated to ensure that off-diagonal values are far from 1 or -1, otherwise the model may be overparametrized (CTSM-R Development Team, 2021). Then, the assumption of white noise and residuals is assessed with the autocorrelation function (ACF) and the cumulated periodogram (Macarulla et al., 2018).

Finally, a simulation with the obtained parameters is run to see if the calculated model can accurately predict the system. The CTSM-R package includes all of the aforementioned statistical tests (CTSM-R Development Team, 2021).

## Results and discussion

Table 4 and Table 5 summarise the results obtained during the validation process.

Table 4: Summary of the model results for each classroom

		A1	A2
Model significance	Overparametrized model?	No	No
	True optimum?	Yes	Yes
	White noise?	Yes	Yes
Model accuracy	RMSE [ppm]	35	49

Values of the root mean square error of the residuals (RMSE) ranged from 35 to 50 (Table 4), values similar to the ones reported in other studies based on grey box modelling approaches (Macarulla et al., 2017). The sensors used to collect the data have an accuracy of  $\pm 50$  ppm +3% of the reading. Consequently, the accuracy reported by the model can be considered to be acceptable.

All statistical tests performed for the parameters in classrooms A1 and A2 are significant. Statistical results show that the p-values are below 0.05 for all estimated parameters. Additionally, none of the values off-diagonal from the autocorrelation matrix is close to 1 or -1 for both classrooms. The derivative of the object function with respect to each other's and the derivative penalty function with respect to the particular initial state or parameters are both close to 0. Therefore, the model is not overparametrized, and the solution found might be a true optimum and not close to the limits.

As shown in Figure 4, it is reasonable to accept that there was no lag dependency in the one-step-ahead prediction

residuals. The cumulated periodogram of the A2 classroom fell slightly outside the 95% confidence interval. However, the flags of the ACF residuals fell mostly inside the 95% confidence interval. Consequently, we can affirm that all models were detailed enough to describe the CO<sub>2</sub> dynamics, and the one-step-ahead residuals obtained could be considered as white noise.

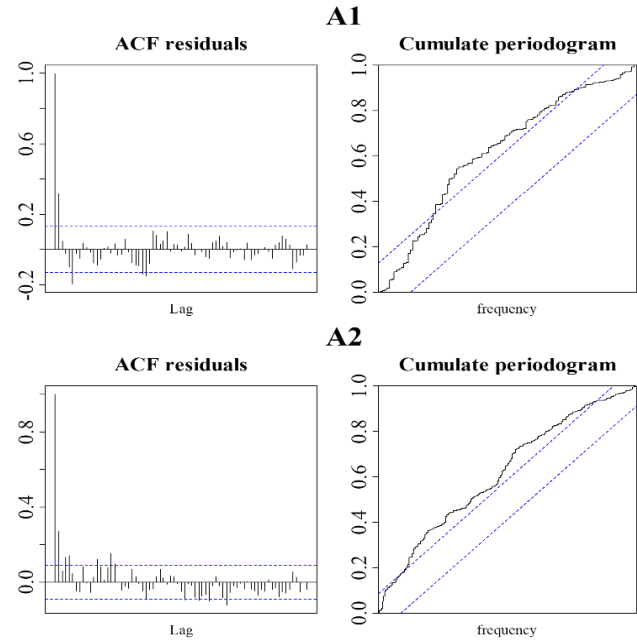

Figure 4: Autocorrelation function (left) and cumulated periodogram (right) of A1 (top) and A2 (bottom) classrooms

All estimated parameters for both classrooms were feasible in terms of the physical sense (Table 5).

Table 5: Physical feasibility of the model for each classroom

Parameter	A1	A2
$C_{ven}$ [ppm]	499	483
$C_{ven}$ standard error [ppm]	50	11
$C_{ven}$ estimation variability [%]	10	2
$K_{occ}$ [l/h]	5.6	7.2
$K_{occ}$ standard error [l/h]	0.3	0.9
$K_{occ}$ estimation variability [%]	4.5	12.8
$Q_d$ [m <sup>3</sup> /h]	-	230
$Q_d$ standard error [m <sup>3</sup> /h]	-	82
$Q_d$ estimation variability [%]	-	36
$Q_w$ [m <sup>3</sup> /h]	-	381
$Q_w$ standard error [m <sup>3</sup> /h]	-	56
$Q_w$ estimation variability [%]	-	14
$Q_x$ [m <sup>3</sup> /h]	265	262
$Q_x$ standard error [m <sup>3</sup> /h]	56	34
$Q_x$ estimation variability [%]	21	13

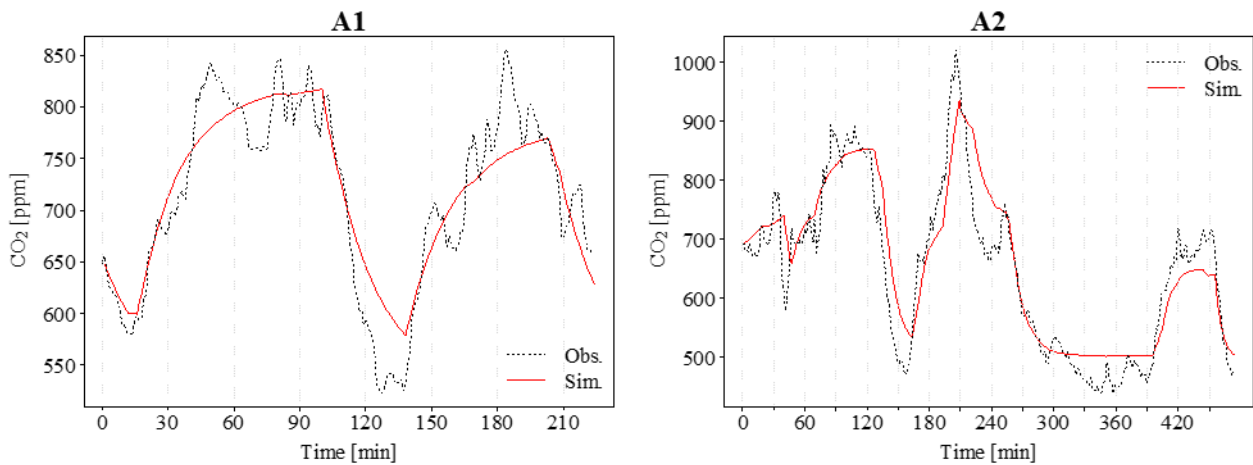

Figure 5: Observed data and simulation of the model from A1 (left) and A2 (right) classrooms.

The estimation of the CO<sub>2</sub> outdoor ventilation ( $C_{ven}$ ) for each classroom is 499 for A1 and 480 ppm for A2, close to the literature values (CSIC, 2020).

The CO<sub>2</sub> human emission rate ( $K_{occ}$ ), was found to be of 5.6 l/h per person in classroom A1 (4 to 5 years old). Checking this value with others reported by previous studies (8.4 l/h per person) it can be concluded that, the value estimated by this model is 33% lower. For the A2 classroom (9 to 10 years old), the difference between the estimated value (7,24 l/h per person) and the one from the literature (11,1 l/h per person), is also found to be 34% lower. This is in line with the results presented by previous studies (Macarulla et al., 2018) which reported values 24% lower for adult's generation rates.

Although the emission rates extracted from the literature are for controlled conditions, the modelling calculations take into account the average activity, gender, body size, and indoor environmental characteristics over the whole period. As a result, the emission rate for the full activity period is reduced due to the indoor environment.

Regarding the ventilation flow rates, for the A1 classroom, only the cross-ventilation air flow ( $Q_x$ ), was found to be significant, because there was just cross-ventilation for the whole period. For all the other air flows, the variability was high and ranged between 13% and 36%. In addition, values were found to be between 57% and 74% lower than the ones established by the Spanish regulations (Spanish Government, 2021) and 27% to 26% lower than the ASHRAE standard 62.1 (ASHRAE, 2019).

As it has been previously exposed, naturally ventilated buildings cannot ensure the proper and constant air flow required by regulations due to the variability of the climatic conditions.

Finally, the observed data of the indoor CO<sub>2</sub> and the deterministic simulation carried by the model for both classrooms are plotted in Figure 5. According to the results of the validation, the model is able to follow, with acceptable accuracy, the evolution of the indoor CO<sub>2</sub> concentration for each classroom.

Although the  $K_{occ}$  values estimated by the model are lower than those presented in the literature, observing the simulation (Figure 5), we can assume that the students' CO<sub>2</sub> emission rate is influenced by the variable conditions of the day, obtaining a lower result with respect to the values calculated under controlled conditions.

On the other hand, as far as natural ventilation is concerned, even if it is below the regulations, the indoor concentration does not exceed 1,000 ppm. Therefore, we can state that, with the opening of doors and windows, natural ventilation is able to mitigate the CO<sub>2</sub> load in the air.

According to the preliminary results of the model, current standards regarding airflow requirements for ventilating educational spaces could be reconsidered, as air renewals are based on  $K_{occ}$  obtained under controlled conditions. If the CO<sub>2</sub> generation ratio is lower, the ventilation required to ensure healthy CO<sub>2</sub> levels might also be reduced. In case of naturally ventilated rooms, this would lead to lower energy costs for the heating system of the building (since the temperature drop corresponding to the outside air intake would be lower). In case of building with mechanical ventilation systems, the energy consumption would also diminish since less air renewals should be required.

## Conclusion

This study investigates the use of grey box modelling to estimate the children's' CO<sub>2</sub> emission rate in naturally ventilated classrooms. For this, a set of data has been selected from the IAQ4EDU project (Gaspar et al., 2022).

The method for simulating the indoor CO<sub>2</sub> concentration developed in this paper is presented as a set of stochastic differential equations. The suggested method allows estimating the students' CO<sub>2</sub> emission rate using different inputs: average data from two CO<sub>2</sub> sensors, windows and doors opening behaviour, and the occupancy distribution.

Using the maximum likelihood method, the parameters of the room are determined. A variety of statistical techniques and a physical interpretation of the estimated parameters are used to validate the model. Moreover, the

model has been validated by a physical interpretation of the estimated parameters.

The estimated human CO<sub>2</sub> emission rate was found to be 24%, lower than the literature values from controlled environments, but in line within the results from previous research which had used grey box models for monitoring indoor air quality. Additionally, air flows from the natural ventilation have been estimated and were also lower than the ones established by the standards.

These standards have been established based on human CO<sub>2</sub> generation rates calculated by methods in a controlled environment (Persily & de Jonge, 2017). However, the value found by the model suggests that standards need to be modified based on the human CO<sub>2</sub> generation rates estimated found by the presented model.

The findings of this study can be used to develop a tool to analyse the current ventilation levels in an educational building. The presented model can be integrated into building management systems to optimize the ventilation strategies.

Further research is required to validate the preliminary results obtained in this paper, by extending the experimental campaign. In order to enlarge, relevant statistical data will be collected from educational buildings, increasing time, age ranges, and climatic zones. However, as studies are carried out in public centres, the monitoring process is limited by the scholar's schedule and government willingness.

In addition, this model can be used in the future for optimizing ventilation strategies taking into account both thermal comfort and energy consumption of mechanical system.

## **Acknowledgments**

This research is part of the R&D project IAQ4EDU, reference no. PID2020-117366RB-I00, funded by MCIN/AEI/10.13039/50110001 1033. The Government of Catalonia is gratefully acknowledged for allowing access to public centres.

## References

- Alonso, A., Llanos, J., Escandón, R., and Sendra, J. (2021). Effects of the COVID-19 pandemic on indoor air quality and thermal comfort of primary schools in winter in a Mediterranean climate. *Sustainability*, 13, p.pp.2699.
- ASHRAE (2019). ANSI/ASHRAE Standard 62.1: Ventilation for Acceptable Indoor Air Quality. American Society of Heating, Refrigerating, and Air-Conditioning Engineers, Inc., Atlanta, USA.
- Azuma, K., Kagi, N., Yanagi, U., and Osawa, H. (2018). Effects of low-level inhalation exposure to carbon dioxide in indoor environments: A short review on human health and psychomotor performance. *Environment International*, 121, p.pp.51–56.
- Bacher, P., and Madsen, H. (2011). Identifying suitable models for the heat dynamics of buildings. *Energy and Buildings*, 43, p.pp.1511–1522.
- Brastein, O. M., Perera, D. W. U., Pfeifer, C., and Skeie, N. O. (2018). Parameter estimation for grey box models of building thermal behaviour. *Energy and Buildings*, 169, p.pp.58–68.
- CTSM-R Development Team (2021). Continuous time stochastic modeling in R. User's guide and reference manual. [online] Available at: <https://ctsm.info/> (Accessed: 02 May 2022).
- Di Gilio, A., Palmisani, J., Pulimeno, M., Cerino, F., Cacace, M., Miani, A., and de Gennaro, G. (2021). CO<sub>2</sub> concentration monitoring inside educational buildings as a strategic tool to reduce the risk of Sars-CoV-2 airborne transmission. *Environmental Research*, 202, p.pp.111560
- Franco, A., and Leccese, F. (2020). Measurement of CO<sub>2</sub> concentration for occupancy estimation in educational buildings with energy efficiency purposes. *Journal of Building Engineering*, 32, p.pp.101714.
- Gaspar, K., Gangoellis, M., Casals, M., Ferré-Bigorra, J., and Pujadas, P. (2022). Optimal ventilation strategies for balancing indoor air quality, comfort and energy use in educational buildings. The IAQ4EDU project. Proceedings of the 2022 European Conference on Computing in Construction (EC3): Rhodes, Greece.
- Heracleous, C., and Michael, A. (2019). Experimental assessment of the impact of natural ventilation on indoor air quality and thermal comfort conditions of educational buildings in the Eastern Mediterranean region during the heating period. *Journal of Building Engineering*, 26, p.pp.100917.
- Jiang, F., Tao, S., Tao, Q., Yuan, Y., and Zheng, J. (2022). The effect of louver blinds on the wind-driven cross ventilation of multi-storey buildings. *Journal of Building Engineering*, 54, p.pp.104614.
- Lepore, E., Aguilera Benito, P., Piña Ramírez, C., and Viccione, G. (2021). Indoors ventilation in times of confinement by SARS-CoV-2 epidemic: A comparative approach between Spain and Italy. *Sustainable Cities and Society*, 72, p.pp.103051.
- Li, Y., O'Neill, Z., Zhang, L., Chen, J., Im, P., and DeGraw, J. (2021). Grey box modeling and application for building energy simulations - A critical review. *Renewable and Sustainable Energy*, 146, p.pp.111174.
- Macarulla, M., Casals, M., Carnevali, M., Forcada, N., and Gangoellis, M. (2017). Modelling indoor air carbon dioxide concentration using grey box models. *Building and Environment*, 117, p.pp.146–153.
- Macarulla, M., Casals, M., Forcada, N., Gangoellis, M., and Giretti, A. (2018). Estimation of a room ventilation air change rate using a stochastic grey box modelling approach. *Measurement*, 124, p.pp.539–548.
- Mannan, M., and Al-Ghamdi, S. (2021). Indoor air quality in buildings: a comprehensive review on the factors influencing air pollution in residential and commercial structure. *Research and Public Health*, 18, p.pp.3276.
- Manisalidis, I., Stavropoulou, E., Stavropoulos, A., and Bezirtzoglou, E. (2020). Environmental and health impacts of air pollution: a review. *Frontiers in Public Health*, 8, p.pp.14.
- CSIC. (2020). Guía para ventilación en aulas. Consejo Superior de Investigaciones Científicas. [online] Available at: <http://hdl.handle.net/10261/221538> (Accessed: 22 October 2022).
- Persily, A., and de Jonge, L. (2017). Carbon dioxide generation rates for building occupants. *Indoor Air*, 27, p.pp.868–879.
- Spanish Government (2022). Royal Decree 178/2021, amending Royal Decree 1027/2007, approving the Spanish Thermal Building Regulations. Imprenta Nacional del Boletín Oficial del Estado: Madrid, Spain.
- Spanish Government (2022). Royal Decree 450/2022, amending Royal Decree 314/2006, approving the Technical Building Code. Imprenta Nacional del Boletín Oficial del Estado: Madrid, Spain.
- Tunga, U., Ogutcu, H., Erdogdu, M., Taskiran, F., Gullu, G., and Oymak, S. (2022). Assessment of indoor air quality in schools from Anatolia, Turkey. *Pollution*, 8, pagep.pp. 57–67.
- Wolf, S., Cali, D., Krogstie, J., and Madsen, H. (2019). Carbon dioxide-based occupancy estimation using stochastic differential equations. *Applied Energy*, 236, p.pp.32–41.
- Yang, S., Mahecha, S. D., Moreno, S. A., and Licina, D. (2022). Integration of indoor air quality prediction into healthy building design. *Sustainability*, 14, p.pp.7890.
- Yoon, C., Zhang, N., Kang, K., Na, H. S., Choi, H., and Kim, T. (2022). Occupant behavior and indoor particulate concentrations in daycare centers. *Science of the Total Environment*, 824, p.pp.153206.